

Proportional Pressure Reducing Valves

K(A)X(C)G-6/8, 1* Series

Basic Characteristics

Max. inlet pressure . . . 350 bar (5000 psi)
 Max. reduced pressure 330 bar (4750 psi)
 Max. flow rate . . . 300 L/min (80 USgpm)
 Mounting face to ISO 5781 (B port high pressure inlet):
 For K(A)X(C)G-6 AG-06-2-A
 For K(A)X(C)G-8 AH-08-2-A

General Description

These two-stage pressure reducing valves (based on Vickers type X(C)G2V valves, featured in catalog 2321) incorporate an electro-hydraulic proportional pressure pilot stage (Vickers type KCG-3 valve, described in catalog 2162) by which the reduced pressure setting is adjustable in response to an electrical input. Each model (in two sizes, with optional free reverse flow check valve) responds to variations of current input to its solenoid, for which separate Vickers drive amplifiers, with PWM output stage and output current control, are available.

Design Features

A maximum outlet pressure to suit the application requirements is preset by the manual adjustment. Below this maximum setting, the outlet pressure is controlled by the solenoid operated proportional pilot valve, according to the current applied to the solenoid.

The “normally open” condition of the mainstage allows full flow from inlet to outlet port until the required reduced pressure is reached, whereupon the mainstage closes, or reduces the flow sufficient only to maintain the required outlet pressure.

High valve response ensures that the reduced outlet pressure is unaffected by inlet pressure peaks. Excess build-up of outlet pressure (during long holding periods, or flow back from an actuator reacting to an overload) is prevented by the small check valve in the mainstage spool, allowing fluid to bleed-off across the pilot stage.

KAX(C)G-6/8

The addition of an integral amplifier allows the pressure to be controlled from a 0 to +10V, or 0 to -10V command signal range. The amplifier is mounted in a robust metal housing and electrical

connections are via an industry standard 7-pin plug. Factory-set adjustments ensure high reproducibility valve-to-valve.

Features and Benefits

- Remote electrical proportional control of reduced pressure from a choice of five pressure ranges per valve size.
- Excellent repeatability and stable performance results from cartridge design of mainstage parts.
- Low installed cost and space requirement from high power/size ratios (more than double that of many conventional designs).

KX(C)G-6 Valve with Type “U” Coil Connection

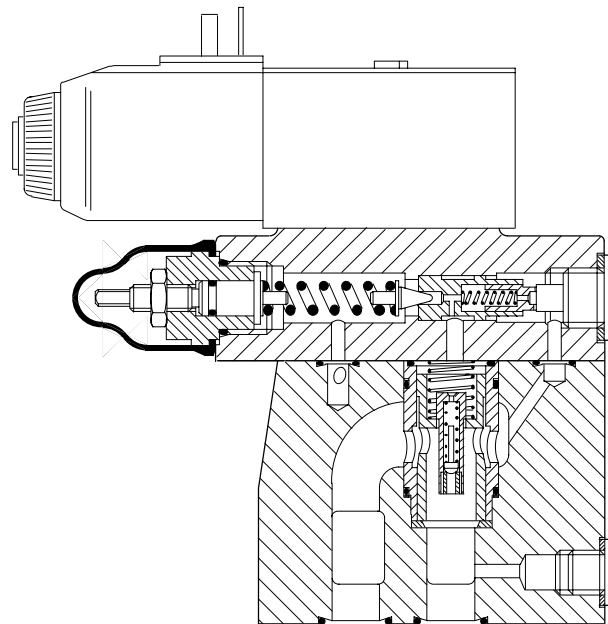

This product has been designed and tested to meet specific standards outlined in the European Electromagnetic Compatibility Directive (EMC) 89/336/EEC, amended by 91/263/EEC, 92/31/EEC and 93/68/EEC, article 5. For instructions on installation requirements to achieve effective protection levels, see this leaflet, the Installation Wiring Practices for Vickers Electronic Products leaflet 2468 and leaflet 02-123931A which is packed with every KA valve. Wiring practices relevant to this Directive are indicated by Electromagnetic Compatibility (EMC).

Functional Symbols

Manual and Electrical Pilots

Drained to Port Y:

Model Code 7 = Blank

Symbol for KXCG models.

For KXG models omit check and internal connection A-B.

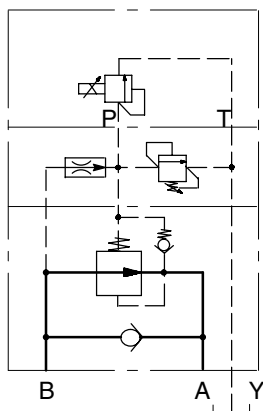

Manual and Electrical Pilots

Drained to Port Y:

Model Code 7 = Blank

Symbol for KAXCG, models with integral amplifier.

For KAXG models omit check and internal connection A-B.

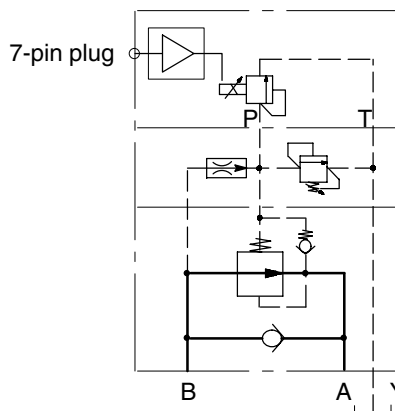

Manual Pilot Drained to Port Y;

Electrical Pilot Drained to Port Y1◆:

Model Code 7 = 3

Symbol for KXG models.

For KXCG models add check valve symbol and internal connection A-B.

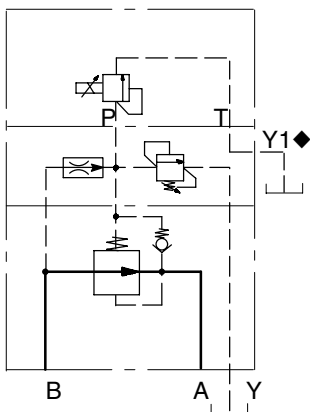

Manual Pilot Drained to Port Y;

Electrical Pilot Drained to Port Y1◆:

Model Code 7 = 3

Symbol for KAXG, models with integral amplifier.

For KAXCG models add check valve symbol and internal connection A-B.

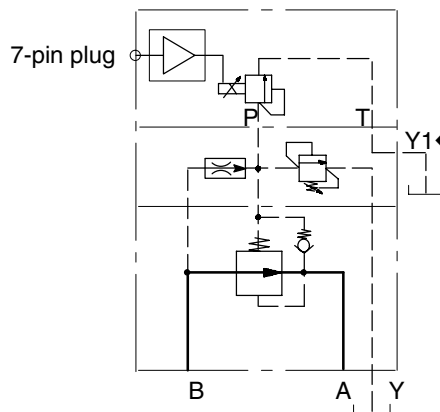

Model Code

Features in brackets () may be omitted. All other features must be specified.

Models requiring separate amplifiers

(F3-)KX(C)G- * - * * -* Z-M- *** - *** -1*(-EN46)**

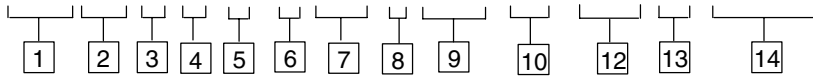

Models with integral amplifier

(F3-)KAX(C)G- * - * * -* Z-M-PD7- H1 -1***

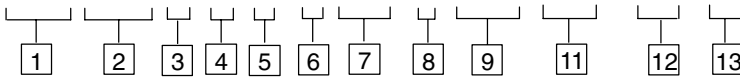

1 Fluid compatibility

Blank = Antiwear hydraulic oil (class L-HM)
 F3 = As above or phosphate ester (class L-HFD)

2 Valve type

KX = Proportional pressure relief
 KAX = Proportional pressure relief with integral amplifier

3 Reverse flow check

C = Reverse flow check
 Omit if not required

4 Mounting type

G = Subplate mounted

5 Mounting surface, ISO 6264

With port B high pressure inlet and port A reduced pressure outlet
 6 = AR-06-2-A
 8 = AS-08-2-A

6 Type of manual adjustment

K = Micrometer with keylock
 M = Micrometer without keylock
 W = Screw/locknut

Note: Reduced pressure adjustment range [7] is based on an inlet pressure of 350 bar (5000 psi). With an inlet pressure of 100 bar (1450 psi) the lower limits are 2 to 3 bar (30 to 40 psi) lower.

7 Reduced pressure adjustment control range (see footnote)

(All coils except type HJ, see position [12] footnote ■)
 40 = 10 - 40 bar (145 - 580 psi)
 100 = 12 - 100 bar (175 - 1450 psi)
 160 = 14 - 160 bar (200 - 2300 psi)
 250 = 15 - 250 bar (220 - 3600 psi)
 330 = 15 - 330 bar (220 - 4750 psi)

8 Pilot drain options

See also "Functional Symbols"

9 Standard features

Z-M = For KX(C)G-6/8 and KAX(C)G-6/8

10 Coil connection type (KCG only)

U = ISO 4400 (DIN43650) interface▼
 FW = Flying-leads in wiring box tapped 1/2" NPT
 FTW = As "FW" plus terminal strip
 FJ = Flying-leads in wiring box tapped M20
 FTJ = As "FJ" plus terminal strip
 P = Plug-in coil (type "H" only) Use with "EN46"

▼ Female connector to be supplied by user.

11 Connections (KACG only)

PD7 = 7 pin connector with plastic plug.
 See **Warning** note regarding CE compliance on page . 12

12 Coil rating

Code = amps x ohms◆
 G1 = 3,5 x 1,65
 GP1 = 3,0 x 2,0
 H1 = 1,6 x 7,3▼
 HA1 = 0,94 x 22
 HJ1 = 1,0 x 14,25■
 HL1 = 0,80 x 29●

◆ Resistance at 20° C (68° F).

▼ KACG valves must have H1 coils
 1 For valves replacing CGEV models.

■ This lower power coil is limited to the following maximum controlled pressures. Valves supplied with type HJ coils will be stamped with the applicable maximum controlled pressure.

| Model code position [7] | Max. pressure with HJ coil |
|-------------------------|----------------------------|
| 40 | 35 bar (500 psi) |
| 100 | 85 bar (1100 psi) |
| 160 | 140 bar (2000 psi) |
| 250 | 210 bar (3000 psi) |
| 330 | 315 bar (4500 psi) |

13 Design number, 1* series

Subject to change. Installation dimensions unaltered for design numbers 10 to 19 inclusive.

14 Special features

EN46 used with P-type coil connection and Uniplug connector.
 Omit if not required.

Operating Data

Standard test conditions are with antiwear hydraulic oil at 36 cSt (168 SUS) and 50°C (122°F)

| | |
|--|--|
| Maximum pressures: Port B (pressure inlet) Port A (reduced pressure outlet) Port Y▲ and side drain port Y1▲ ▲ Back pressure at these ports is additive to the reduced pressure setting of the valve. | 350 bar (5000 psi) See [7] in "Model Code" 2 bar (30 psi) |
| Rated flow at $\Delta p = 12$ bar (175 psi) and 0 mA to coil: K(A)X(C)G-6 K(A)X(C)G-8 | 200 L/min (53 USgpm) 300 L/min (80 USgpm) |
| Pressure adjustment ranges | See [7] in "Model Code" |
| Minimum pressure differential ($P_B - P_A$) for effective reduced pressure control, all models | 20 bar (300 psi) |
| Pilot control drain flow, all models | 1,5 L/min (0.4 USgpm) max. |
| Coil or amplifier rating KX(C)G KAX(C)G | See [12] in "Model Code" 24V x 40W max. (22 to 36V incl. 10% pk. to pk. max.ripple) |
| Command signal ranges, KAC(C)G models | 0 to +10V DC, or 0 to – 10V DC |
| Dither, KAX(C)G models | Factory set, not user adjustable |
| Monitor point signal, KAX(C)G models | 0,5V per amp. solenoid current |
| Power stage PWM, KAX(C)G models | 2kHz nominal |
| 7-pin plug connections, KAX(C)G models: A B C D E F G | Power supply +ve Power 0V Signal 0V +ve voltage command signal –ve voltage command signal Monitor output Protective ground |
| Electro-magnetic compatibility (EMC) KAX(C)G models only: Emission (10v/m) Immunity (10v/m) | EN 50081-2 EN 50082-2 |
| Pressure gain Factory setting - Maximum with 10V command signal. User adjustment - 30 to 120% of factory setting. Note that altering this setting will affect valve to valve interchangeability. | See graph |
| Pressure override | See graph |
| Hysteresis, using Vickers drive amplifier KX(C)G KAX(C)G | <6% <7% |
| Linearity at conditions: 1. "Dead-head" (no flow from reduced pressure outlet port) 2. Between 10% and 100% rated pressure | <6% of rated pressure |
| Repeatability | < ± 1,3% of rated pressure |
| Protection, Electrical (KA(C)G models) | Reverse-polarity protected |

| | |
|---|---|
| Mass (weight) | |
| KCG-6 | 4,9 kg (10.8 lb) |
| KACG-6 | 5,3 kg (11.7 lb) |
| KCG-8 | 5,8 kg (12.8 lb) |
| KACG-8 | 6,2 kg (13.7 lb) |
| Supporting products: | |
| Amplifiers for KCG valves with "H" type coils only: | |
| EHH-AMP-724-C/D-10 (Uniplug) | See catalog 2367 |
| EHH-AMP-7*2 series (power plug) | See catalogs 2114, 2115 and 2282 |
| EEA-PAM-513-A-14 (1 adjustable ramp) | See catalog 2137 |
| EEA-PAM-513-A-3* (2 adjustable ramps) | See catalog 2464 |
| Auxilliary electronic modules (Din-rail mounting) for KACG models: | |
| EHA CON 201 A 2* signal converter | See catalog 2410B |
| EHD DSG 201 A 1* command signal generator | See catalog 2470 |
| EHA RMP 201 A 2* ramp generator | See catalog 2410B |
| EHA PID 201 A 2* PID controller | See catalog 2427 |
| EHA PSU 201 A 1* power supply | See catalog 2410B |
| ISO 4400 (DIN 43650) electrical connector: | |
| Black, marked "B" | Part number 710775 |
| Gray, marked "A" | Part number 710776 |
| Subplates, size 03 | See catalog 2425 |
| Mounting bolts■ | See catalog 2314A |
| ■ <i>Note: If not using Vickers recommended bolt kits, bolts must be to ISO 898 grade 12.9 or stronger.</i> | |
| Installation and start-up (commissioning): | |
| Installation and start-up (commissioning) guide | ML-B-9133B (Multi-lingual English, German, French and Italian), shipped with each product and also available separately on request. |
| Mounting attitude | No restriction, provided that the valve is kept full of fluid through port T. |
| Ordering procedure | Valves, subplates, bolt kits and Vickers amplifiers should be ordered by full model code designation. Order ISO (DIN) electrical connectors by part number. |

Performance Data

Typical with oil at 36 cSt (168 SUS) and at 50°C (122°F)

Pressure Override

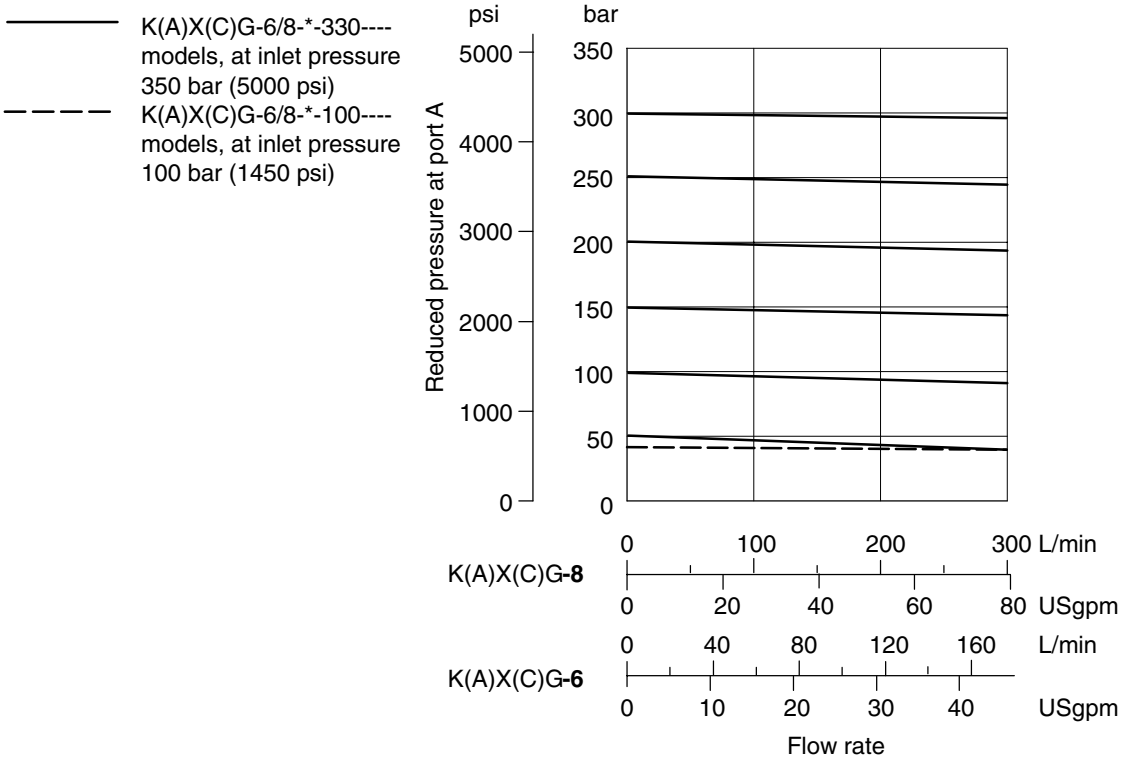

Pressure Drop

From port B to A at pressures below reduced pressure setting:

K(A)X(C)G-6 valves Curve A
 K(A)X(C)G-8 valves Curve B

From port A to B through check valve (mainstage assumed closed).

Types K(A)XCG only:
 K(A)XCG-6 valves Curve C
 K(A)XCG-8 valves Curve D

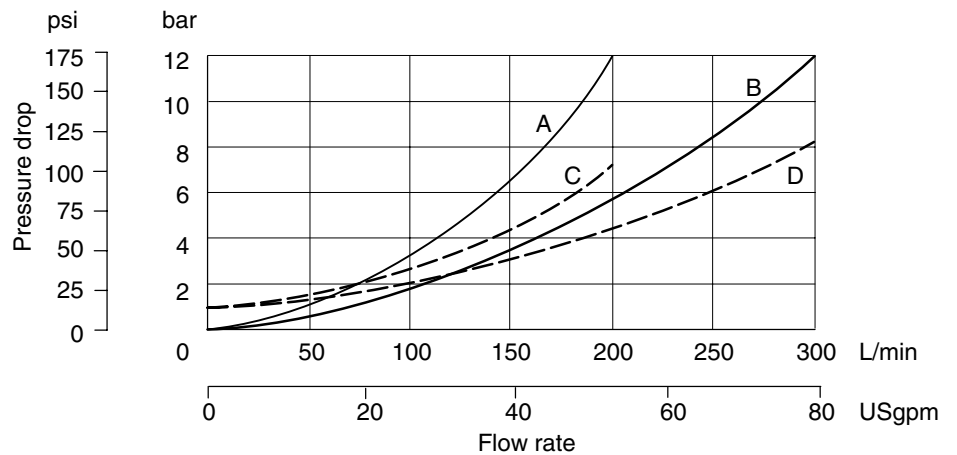

Pressure Gain

Typical example K(A)X(C)G-6/8-*-250, at inlet pressure 350 bar (5000 psi). Valid for models driven from Vickers amplifier with appropriate settings of gain and offset.



Step Response

Typical data for K(A)X(C)G-*-250 model with factory settings of gain and offset and KX(C)G-*-250 driven by Vickers Eurocard amplifier with appropriate settings of gain and offset, and with a ramp time of 80 ms ▲.

▲ Recommended minimum ramp rate to avoid excessive pressure overshoot: 80 ms/100% solenoid current.

| Valve size | Test conditions: Trapped volume | Flow rate | Step size: Pressure demand | Response time (ms) |
|------------|------------------------------------|-------------------------|-------------------------------|--------------------|
| 6 | 1,5 liters (0.4 USg) | 75 L/min (20 USgpm) | 0 to 100% | 75 |
| | | | 100% to 0 | 60 |
| | | | 25 to 100% | 60 |
| | | | 100 to 25% | 50 |
| 8 | 3,0 liters (0.8 USg) | 150 L/min (40 USgpm) | 0 to 100% | 70 |
| | | | 100% to 0 | 70 |
| | | | 25 to 100% | 45 |
| | | | 100 to 25% | 70 |

Test method

- Inlet pressure set 300 bar (4350 psi)
- Trapped volume as in table
- Steady state flow rate adjusted by downstream throttle valve with $\Delta p = 250$ bar (3600 psi)
- Response = time from step input signal until reduced output pressure reaches 90% of step change, as measured by transducer

Test Circuit

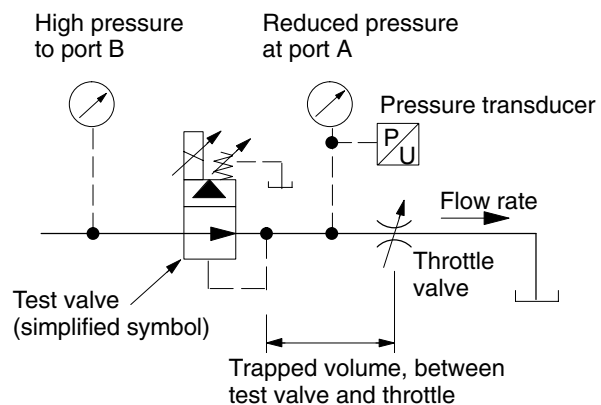

KAX(C)G-6/8 Electrical Block Diagram

Wiring

Connections must be made via the 7-pin plug mounted on the amplifier.
Recommended cable sizes are:

Power cables:

For 24V supply

0,75 mm² (18 AWG) up to 20m (65 ft)

1,00 mm² (17 AWG) up to 40m (130 ft)

Signal cables:

0,50 mm² (20 AWG)

Screen:

A suitable cable would have 7 cores, a separate screen for the signal wires and an overall screen.

See wiring connection diagram on page

NO TAG

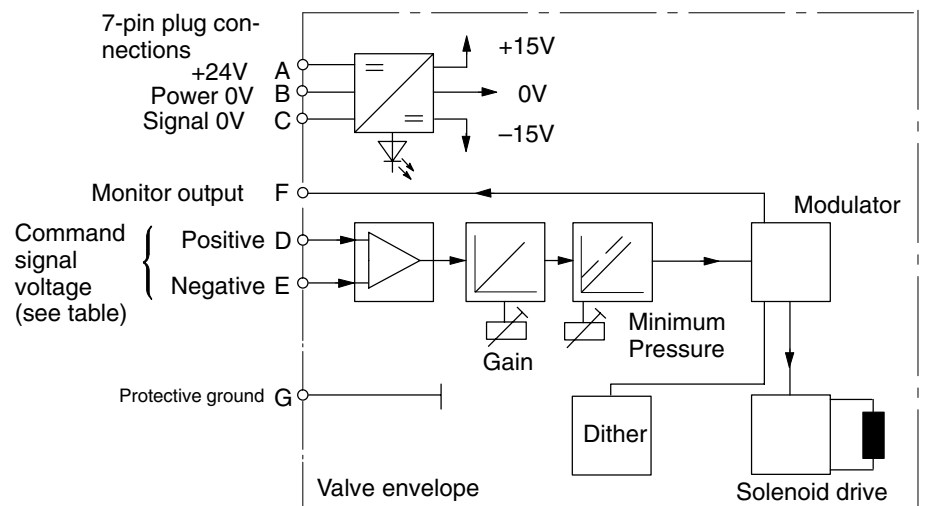

Warning

All power must be switched off before connecting or disconnecting any plugs.

KAX(C)G-6/8 Typical Connection Arrangements

Wiring Connections for Valves with integral Amplifier

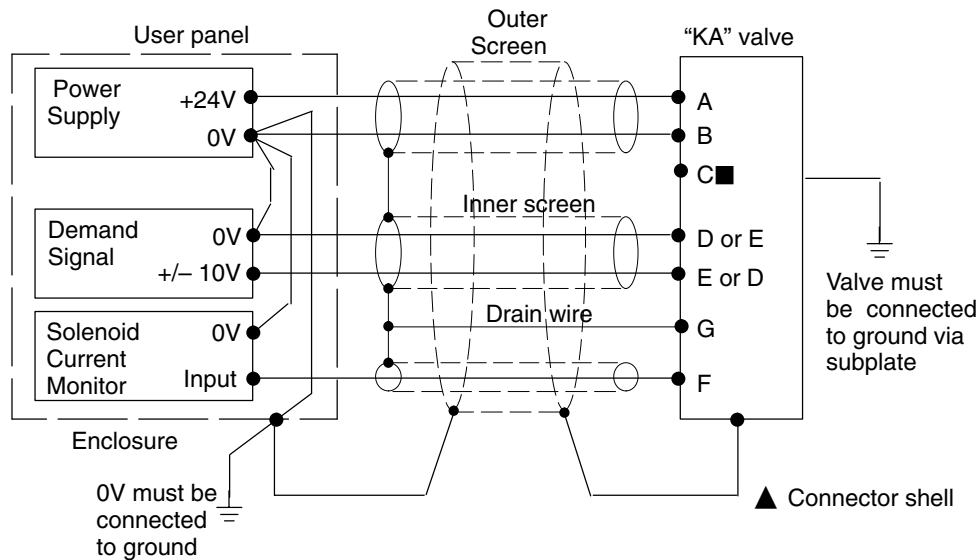

■ Solenoid current monitor voltage (pin F) will be referenced to the KA valve local ground. A “local ground” (pin C) is provided for optional use by differential input customer supplied electronics.

▲ Note: In applications where the valve must conform to European RFI/EMC regulations, the outer screen (shield) must be connected to the outer shell of the 7-pin connector and the valve body must be fastened to the earth ground. Proper earth grounding practices must be observed in this case, as any differences in command source and valve ground potentials will result in a screen (shield) ground loop.



Warning

Do not ground pin C. If the local ground (pin C) is not used for differential monitor electronics, do not use. Read monitor pin F with respect to ground.



Warning

Electromagnetic Compatibility (EMC)

It is necessary to ensure that the valve is wired-up as above. For effective protection, the user electrical cabinet, the valve subplate or manifold, and the cable screens should be connected to efficient ground points. The metal 7-point connector, part no. 934939, should be used for the integral amplifier.

In all cases, both valve and cable should be kept as far as possible from any sources of electromagnetic radiation such as cables carrying heavy current, relays and certain kinds of portable radio transmitters, etc. Difficult environments could mean that extra screening may be necessary to avoid the interference.

It is important to connect the 0V lines as shown above. The multi-core cable should have at least two screens to separate the demand signal and monitor output from the power lines.

Installation Dimensions in mm (inches)

KX(C)G-* Models with Type "U" Coil Connection:
"U" at Model Code 9

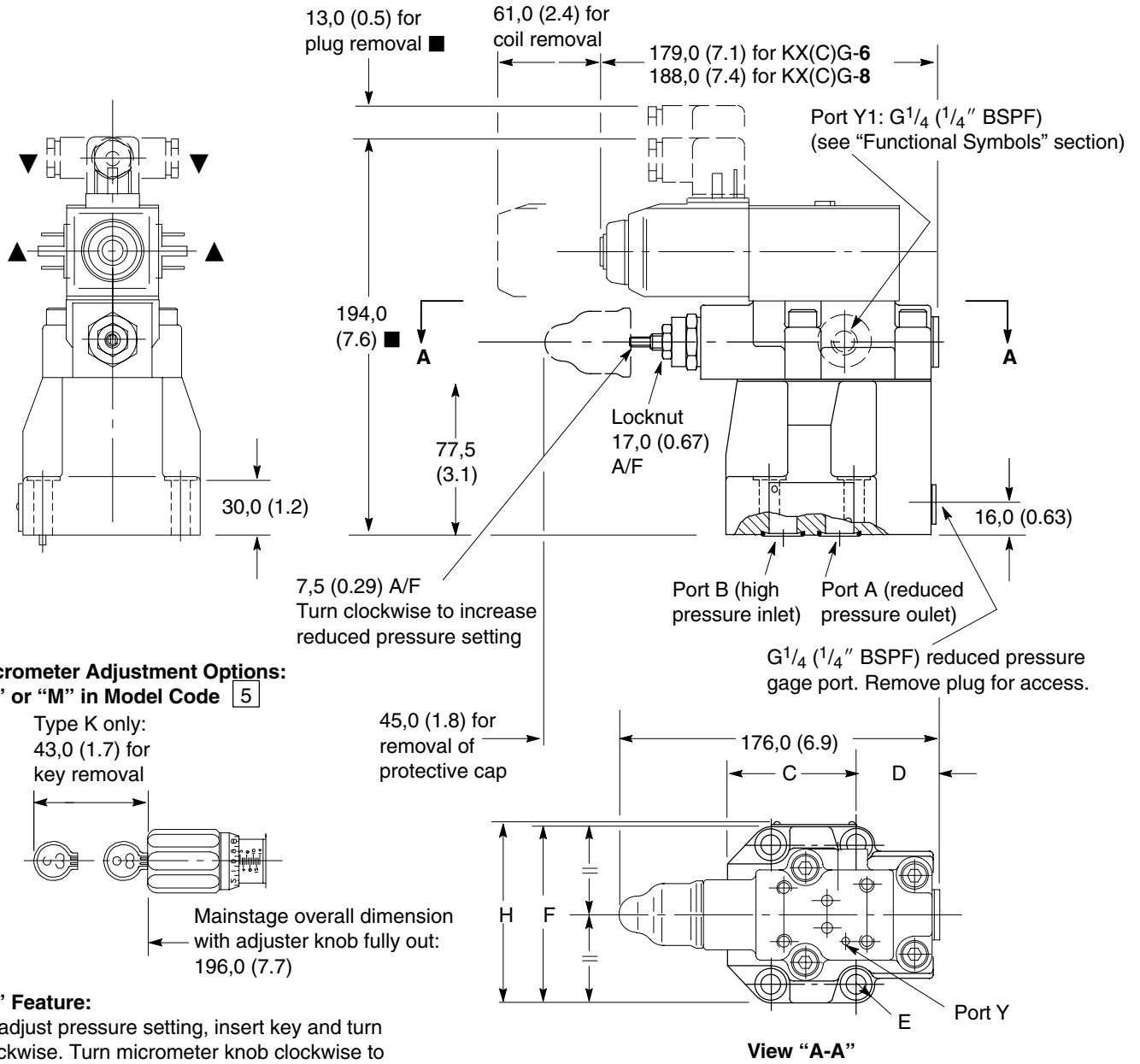
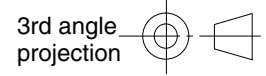

Micrometer Adjustment Options:
"K" or "M" in Model Code 5

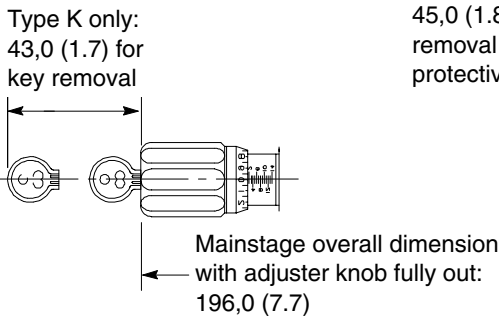

"K" Feature:

To adjust pressure setting, insert key and turn clockwise. Turn micrometer knob clockwise to increase pressure setting; counter-clockwise to decrease setting. When the key is removed the knob can spin freely without affecting the pressure setting.

- ▲ Alternative plug positions by loosening knurled nut counter-clockwise, turning coil and re-tightening nut.
- Dimensions may vary according to source of plug.
- ▼ The cable entry on this plug can be repositioned at 90° intervals by reassembly of the contact holder relative to the plug housing. The cable entry is Pg 11 for cables Ø6-10 mm (0.24-0.4 dia).

| Model | C | D | E rad. | F | H |
|----------|---------------|---------------|----------------|----------------|-----------------|
| KX(C)G-6 | 42,0 (1.7) | 66,0 (2.6) | 10,0 (0.4) | 89,0 (3.5) | 92,0 (3.65) |
| KX(C)G-8 | 40,0 (1.6) | 77,0 (3.1) | 11,0 (0.43) | 104,0 (4.1) | 107,0 (4.25) |

**KX(C)G-* Models with Type "F" Coil Connection:
"F(T)W" or "F(T)J" at Model Code 7**

For dimensions not shown see page 10.

3rd angle projection

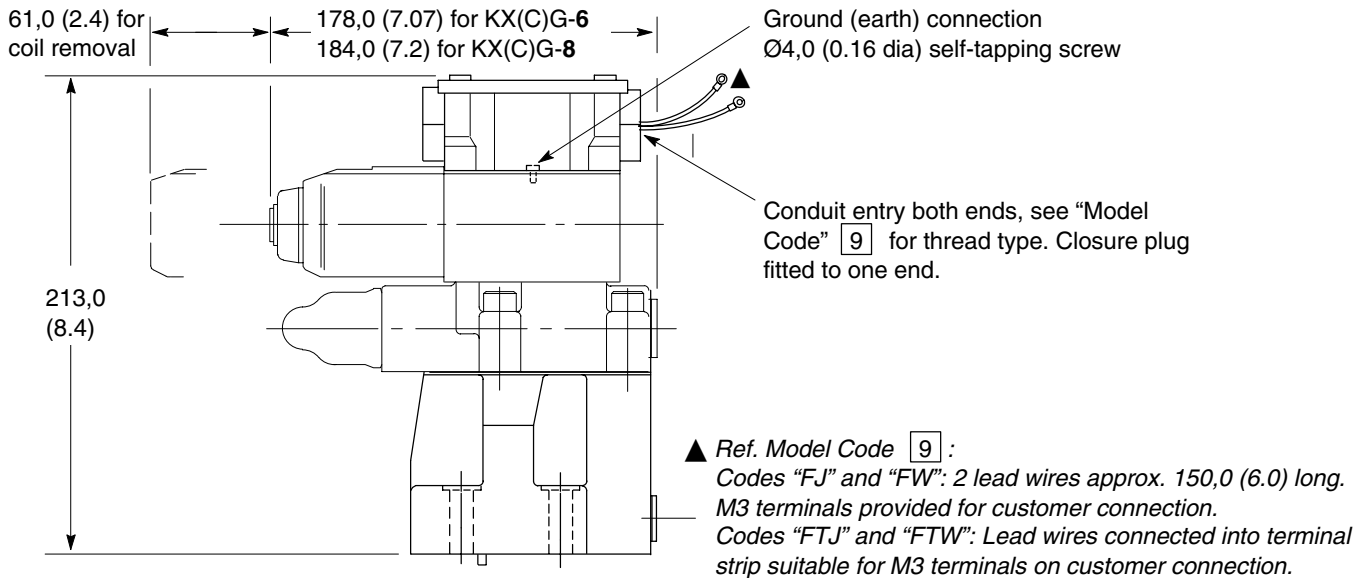
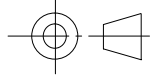

**KX(C)G-*---EN46 Models for Use with Vickers
UNIPLUG, Single Cable Connector:**

"P" at Model Code 11; "H" at Model Code 11

For use with Vickers single-cable UNIPLUG connectors:

For "Soft Switch" Control:

Use UNIPLUG model type EHH-AMP-724-C*-1*

For Proportional Control:

Use UNIPLUG model type EHH-AMP-724-D*-1*

UNIPLUG connectors should be ordered separately; see catalog 2367.

To fit UNIPLUG connector to KCG-3 pilot valve:

Unscrew coil retention nut and remove coil.

Slide UNIPLUG connector onto dummy pins (at non-solenoid end) then replace coil, ensuring pins are fully engaged.

Replace and tighten coil retention nut.

For dimensions not shown see page 10.

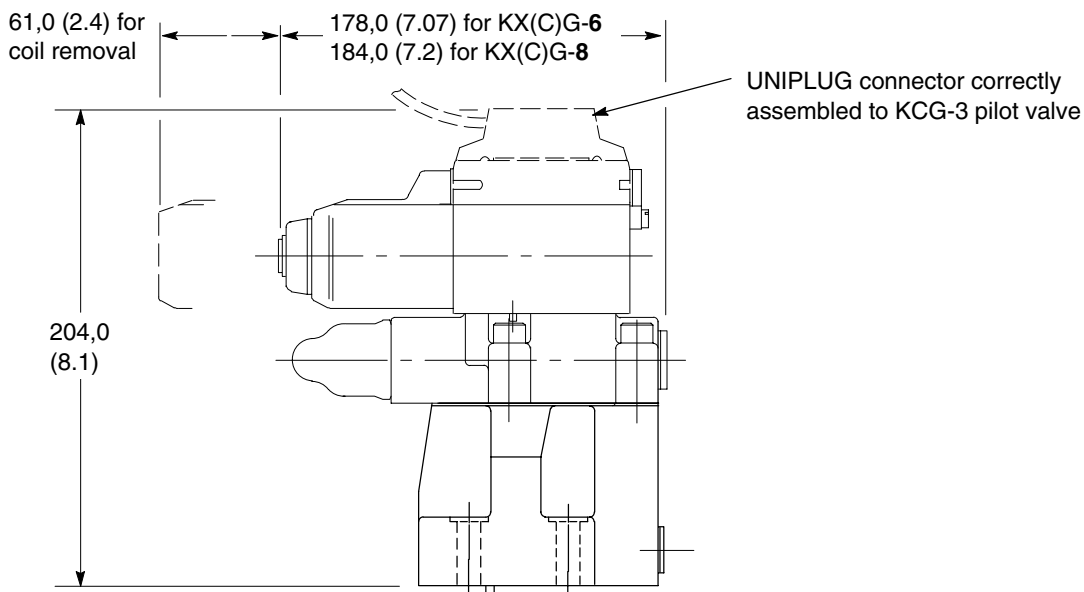

KAX(C)G-* Models (With integrated amplifier)

Metal plug 934939

Cable outside diameter 8,0 to 10,5 (0.31 to 0.41)
Must be used for full EMC protection. See also warning note below

Plastic plug 694534

PG11. Cable maximum outside diameter 11,0 (0.43)

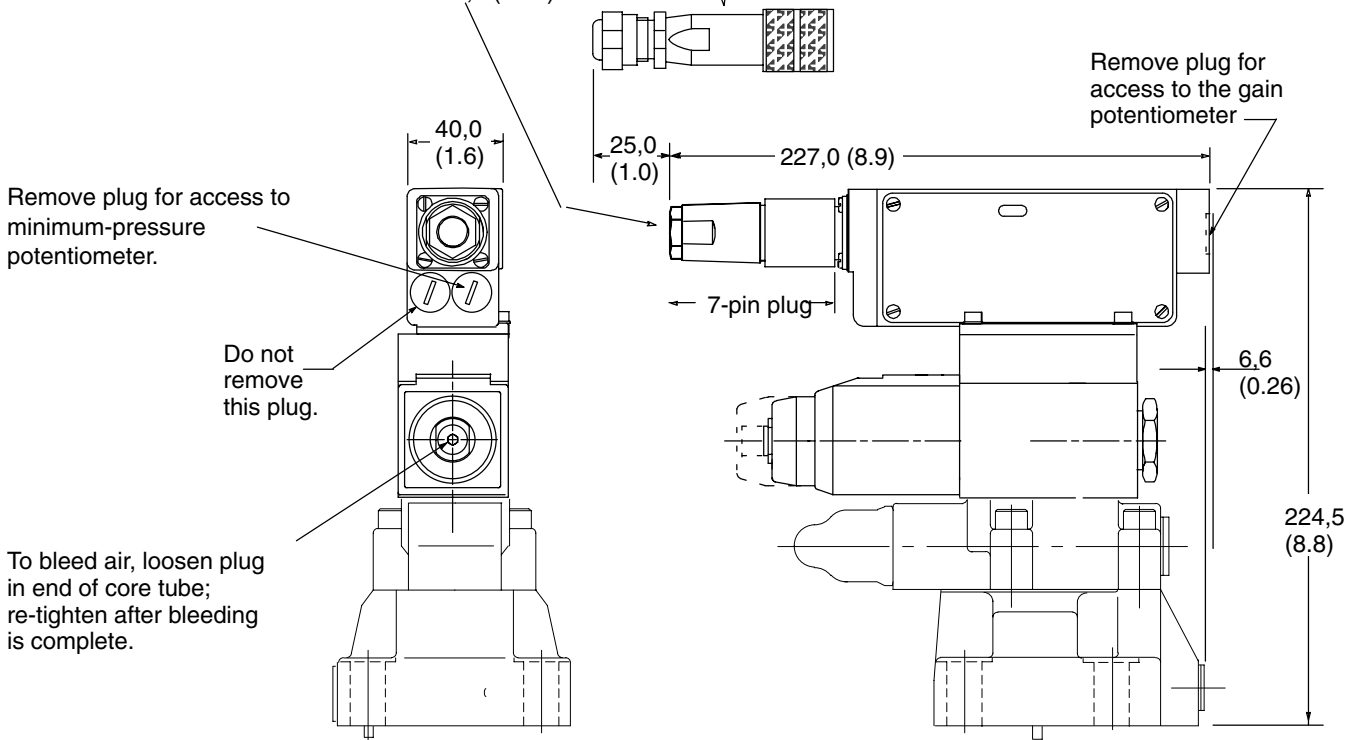

Warning

To conform to the EC Electromagnetic Compatibility directive (EMC) this KACG valve must be fitted with a metal 7-pin plug. The screen of the cable must be securely connected to the shell of the metal connector. A suitable IP67 rated connector is available from Vickers, part no. 934939. Alternatively a non IP67 rated connector is available from ITT-Cannon, part no. CA 02 COM-E 14S A7 P.

Additionally the cable must be fitted with a ferrite EMC suppression core not more than 4cm from the connector referred to above. Suitable types include Farnell 535-898 or Farnell 535-904 which snap fit over the cable.

The plastic plug, part number 694534, is only suitable for use in a sealed electromagnetic environment or outside of the European Community.

Mounting Surfaces, ISO 5781

(B Port High Pressure Inlet)

AG-06-2-A

AH-08-2-A

When a subplate is not used a raised machined pad must be provided for mounting. The pad must be flat within 0,001 mm/100 mm (0.0001"/10") and smooth within 0,8 µm (32 µin).

Dimensional tolerances are ±0,2 mm (±0.008") except where indicated.

Port functions

A = Reduced pressure outlet (Also free reverse flow inlet for KXCG valves)

B = High pressure inlet (Also free reverse flow outlet for KXCG valves)

X = Not used for KX(C)G valves; can be omitted or plugged

Y = Drain port

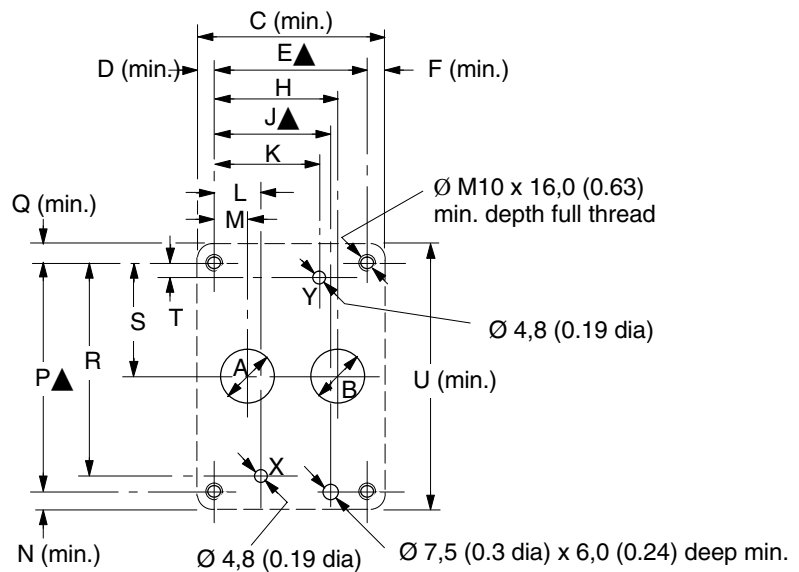

| Size | A dia. | B dia. | C | D | E | F | H | J | K |
|------|-------------|-------------|------------|------------|-------------|------------|-------------|-------------|-------------|
| 06 | 14,7 (0.58) | 14,7 (0.58) | 61,0 (2.4) | 9,0 (0.4) | 42,9 (1.69) | 9,0 (0.4) | 35,7 (1.4) | 31,8 (1.25) | 21,4 (0.84) |
| 08 | 23,4 (0.92) | 23,4 (0.92) | 78,0 (3.1) | 8,8 (0.35) | 60,3 (2.37) | 8,8 (0.35) | 49,2 (1.94) | 44,5 (1.75) | 39,7 (1.56) |

| Size | L | M | N | P | Q | R | S | T | U |
|------|-------------|-------------|-------------|--------------|-------------|-------------|-------------|------------|-------------|
| 06 | 21,4 (0.84) | 7,1 (0.28) | 10,0 (0.4) | 66,7 (2.62) | 10,0 (0.4) | 58,7 (2.3) | 33,3 (1.3) | 7,9 (0.31) | 87,0 (3.4) |
| 08 | 20,6 (0.81) | 11,1 (0.44) | 10,8 (0.43) | 79,4 (3.125) | 10,8 (0.43) | 73,0 (2.87) | 39,7 (1.56) | 6,4 (0.25) | 101,0 (4.0) |

▲ Tolerance on bolt and pin locations ± 0,1 mm (± 0.004").

XCGVM-6-10R Subplate

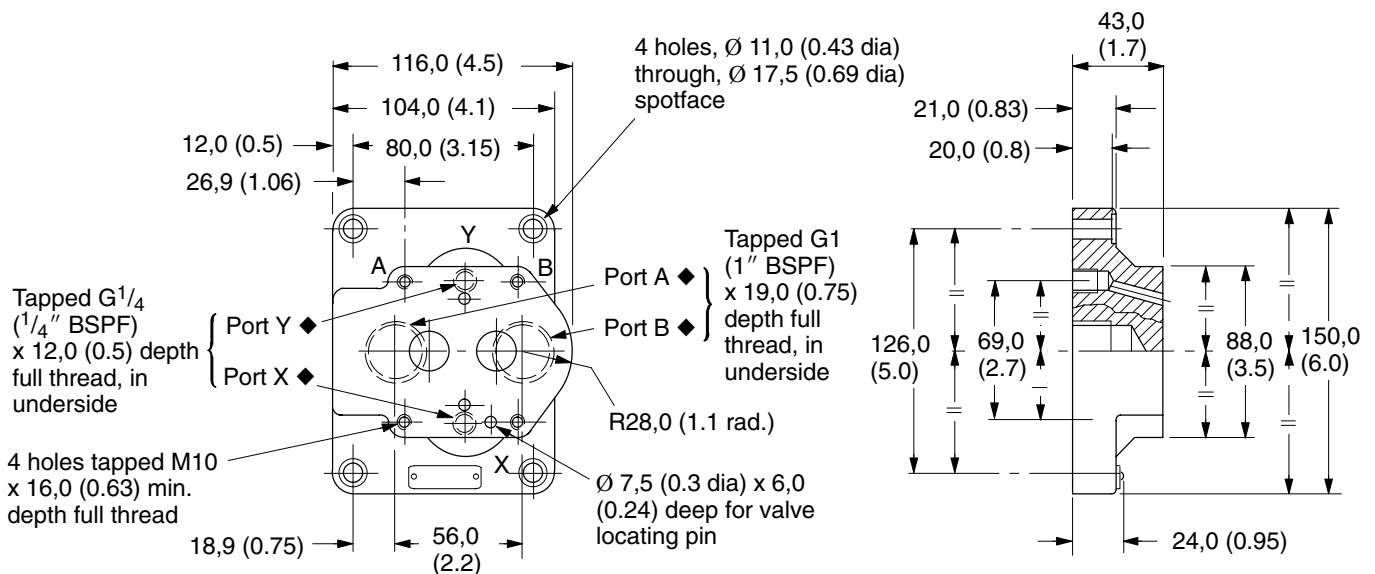

◆ See "Mounting Surfaces" section above for port usage.

Further Information

Hydraulic Fluids

Materials and seals used in these valves are compatible with:

Anti-wear petroleum oils L-HM

For use with Non-alkyl based phosphate esters (L-HFD), use F3 version in model code.

The extreme operating range is 500 to 13 cSt (270 to 70 SUS) but the recommended running range is 54 to 13 cSt (245 to 70 SUS). For further technical information about fluids see 694.

Contamination Control Requirements

Recommendations on contamination control methods and the selection of products to control fluid condition are included in Vickers publication 9132 or 561, "Vickers Guide to Systemic Contamination Control". The book also includes information on the Vickers concept of "ProActive Maintenance". The following recommendations are based on ISO cleanliness levels at 2 µm, 5 µm and 15 µm.

For products in this catalog the recommended levels are:
Up to 210 bar (3000 psi) 18/16/13
Above 210 bar (3000 psi) 17/15/12

Installation and Start-up Guidelines

The proportional valves in this catalog can be mounted in any attitude but it may be necessary, in certain demanding applications, to ensure that the solenoids are kept full of hydraulic fluid.

If this proves to be the case any accumulated air can be bled from the solenoid bleed screw. This task is easier if the valve has been mounted base downwards. Good installation practice dictates that the tank port, and any drain port, are piped so as to keep the valve full of fluid once the system start-up has been completed.

Temperatures

For petroleum oil:

Min. -20°C (-4°F)

Max.* +70°C (158°F)

* *To obtain optimum service life from both fluid and hydraulic system, 65°C (150°F) normally is the maximum temperature.*

For other fluids where limits are outside those of petroleum oil, consult fluid manufacturer or Vickers representative. Whatever the actual temperature range, ensure that viscosities stay within those specified under "Hydraulic Fluids".

Ambient for:

Valves at full performance specification:
-20 to +60°C (-4 to +140°F).

Valves, as above, will operate at temperatures of 0 to -20°C (32 to -4°F) but with a reduced dynamic response.

Storage:

-25 to +85°C (-13 to +185°F)

Eurocard electronics:

0 to 50°C (32 to 122°F)

Seal Kits

Pilot valves

K(A)CG-3 (KA + DIN) 02-138201

KCG-3 ('F' & 'P' versions) 02-145869

Mainstage valves

K(A)X(C)G-6 614824

K(A)X(C)G-8 614826